

Features

- Bipolar Hall Effect Latch Sensor
- 3.5V to 20V DC Operation Voltage
- Open Collector Pre-Driver
- 50mA Output Sink Current
- Chip Power Reverse-Connection Protection
- Operating Temperature: -40°C~125°C
- Package: SIP3
- SIP3: Available in "Green" Molding Compound (No Br, Sb)
- Lead Free Finish/ RoHS Compliant (Note 1)

General Description

AH1751 is a single-digital-output Hall-effect sensor for high temperature operation. The device includes an on-chip Hall voltage generator for magnetic sensing, an amplifier to amplify Hall voltage, and a comparator to provide switching hysteresis for noise rejection, and an open-collector output pre-driver. An internal band-gap regulator is used to provide temperature compensated supply voltage for internal circuits and allows a wide operating supply range.



While the magnetic flux density (B) is larger than threshold Bop, the OUT pin turns on (low). If B removed toward Brp, the OUT pin is latched "on" state prior to B < Brp. When B < Brp, the OUT pin go into " off " state.

Applications

- Rotor Position Sensing
- Current Switch
- Encoder
- RPM Detection

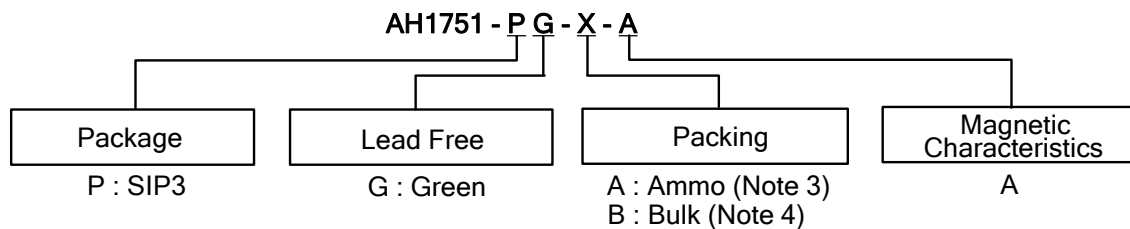
Ordering Information



Device	Package Code	Packaging (Note 2)	Bulk		Ammo Box		Magnetic Characteristics
			Quantity	Part Number Suffix	Quantity	Part Number Suffix	
 AH1751-PG-A-A	P	SIP3	NA	NA	4000/Box	A	A
 AH1751-PG-B-A	P	SIP3	1000	-B	NA	NA	A

- Notes:
1. EU Directive 2002/95/EC (RoHS). All applicable RoHS exemptions applied, see *EU Directive 2002/95/EC Annex Notes*.
 2. Pad layout as shown on Diodes Inc. suggested pad layout document AP02001, which can be found on our website at <http://www.diodes.com/datasheets/ap02001.pdf>.
 3. Ammo Box is for SIP3 Spread Lead.
 4. Bulk is for SIP3 Straight Lead.

Pin Assignment

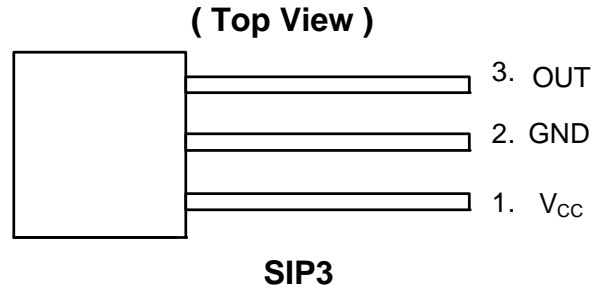

Pin Descriptions

Name	Description
V _{CC}	Input Power
GND	Ground
OUT	Output Stage

Block Diagram

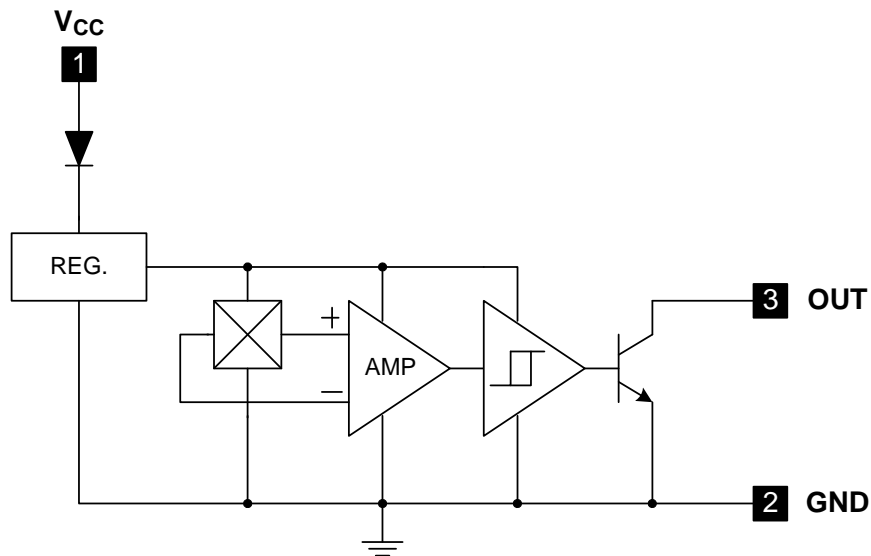

Absolute Maximum Ratings ($T_A = 25^\circ\text{C}$)

Symbol	Parameter	Rating	Unit
V_{CC}	Supply Voltage	20	V
$V_{out (off)}$	Output "OFF" Voltage	20	V
$I_o (sink)$	Output "ON" Current	100	mA
T_{ST}	Storage Temperature Range	-65~+150	$^\circ\text{C}$
$T_{J(MAX)}$	Maximum Junction Temperature	+150	$^\circ\text{C}$
P_D	Power Dissipation	SIP3	mW

Recommended Operating Conditions

Symbol	Parameter	Conditions	Min	Max	Unit
V_{CC}	Supply Voltage	Operating (Note 5)	3.5	20	V
T_A	Operating Temperature Range	Operating	-40	125	$^\circ\text{C}$

Notes: 5. Operating, the output is switching as magnetic field change (S>300G, N<-300G).

Electrical Characteristics ($T_A = 25^\circ\text{C}$)

Symbol	Parameter	Conditions	Min	Typ.	Max	Unit
$V_{out (SAT)}$	Output Saturation Voltage	$V_{CC} = 12\text{V}$, OUT "ON" $I_o = 50\text{mA}$	-	200	300	mV
I_{CC}	Supply Current	$V_{CC} = 12\text{V}$, OUT "OFF"	-	3.5	6	mA

Magnetic Characteristics ($T_A = 25^\circ\text{C}$, $V_{CC} = 4\sim 20\text{V}$, Note 6)

A grade

(1mT = 10 Gauss)

Symbol	Parameter	Min	Typ.	Max	Unit
Bops(south pole to brand side)	Operation Point	5	-	70	Gauss
Brps(south pole to brand side)	Release Point	-70	-	-5	Gauss
$B_{hy}(B_{opx} - B_{rpx})$	Hysteresis	-	75	-	Gauss

Notes: 6. Magnetic characteristics are design information, which will vary with supply voltage, operating temperature and after soldering.

Operating Characteristics

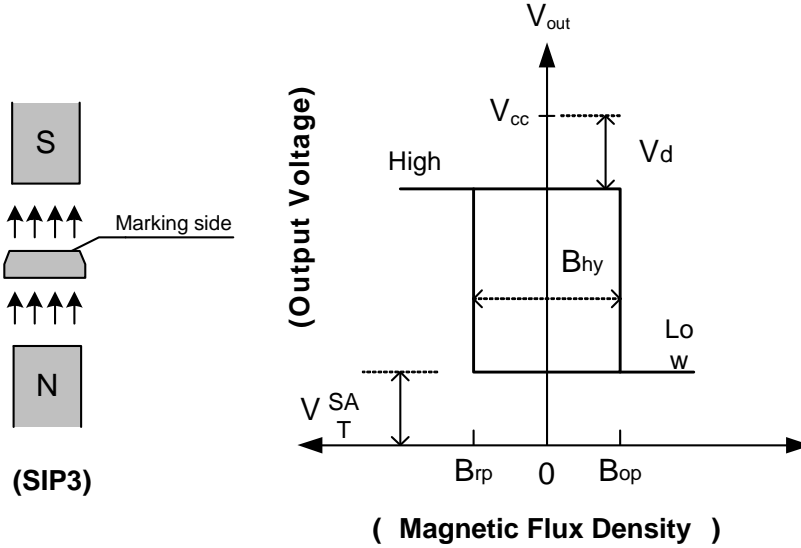

Performance Characteristics

T_A (°C)	25	50	60	70	80	85	90	95	100
P _D (mW)	550	440	396	352	308	286	264	242	220
T_A (°C)	105	110	115	120	125	130	135	140	150
P _D (mW)	198	176	154	132	110	88	66	44	0

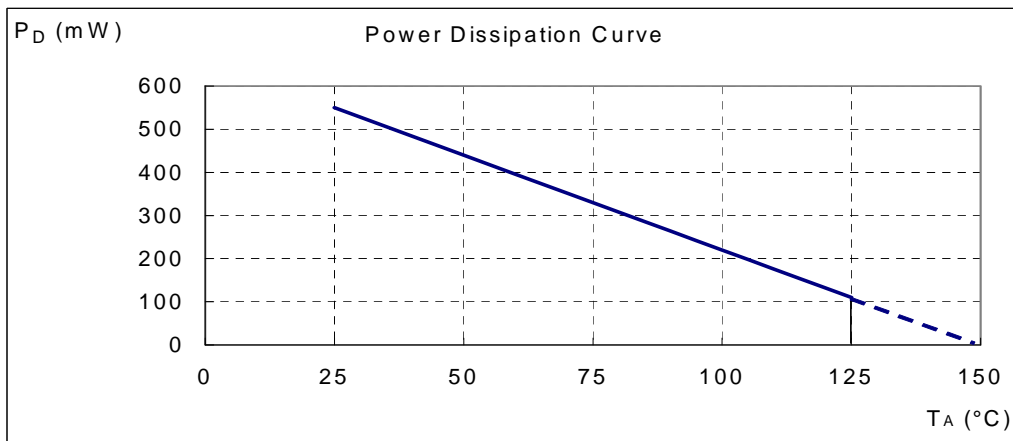

Marking Information

(Top View)

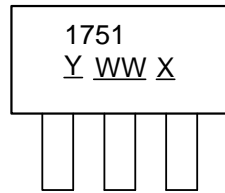

SIP3

Y : Year : "7" = 2007
"8" = 2008
WW : Nth Week 01~52
X : Internal code
A~Z : Green

Package Information (All Dimensions in mm)

(1) Package Type: SIP3 for Bulk pack

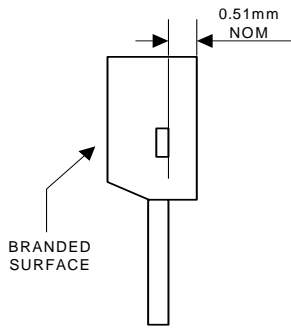

Active Area Depth

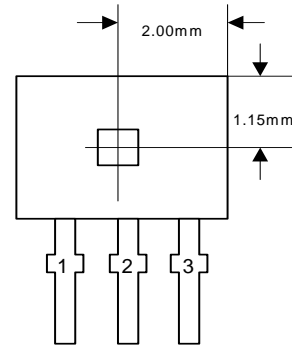

Sensor Location

Package Dimension

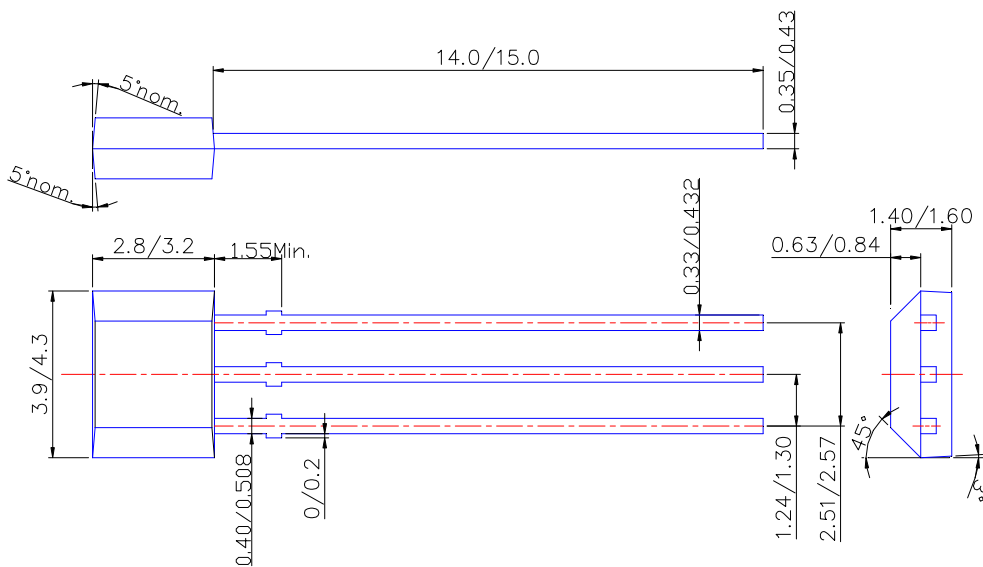

Package Information (Continued)

(2) Package Type: SIP3 for Ammo pack

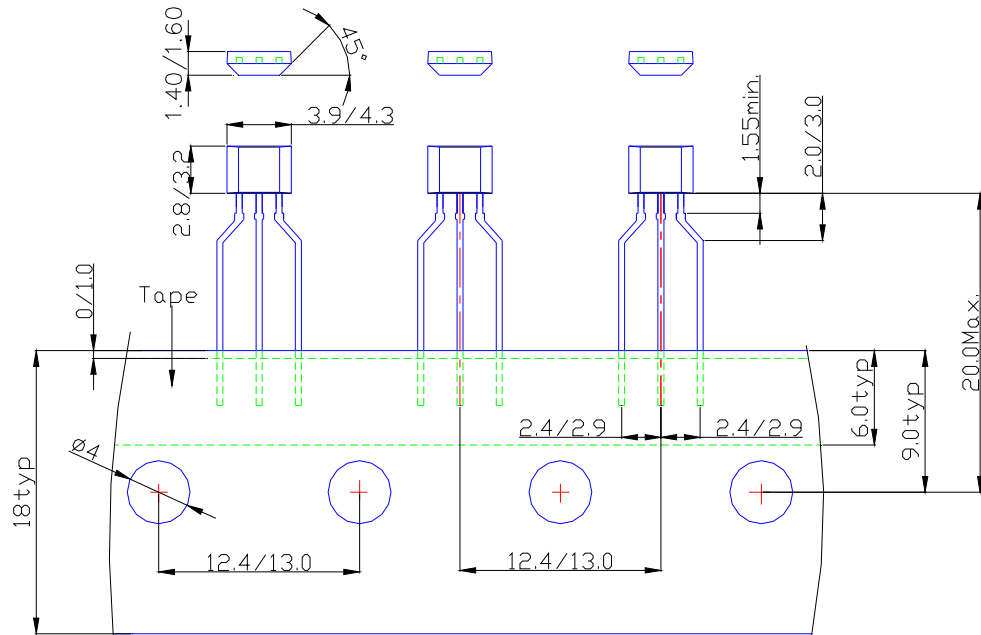

IMPORTANT NOTICE

Diodes Incorporated and its subsidiaries reserve the right to make modifications, enhancements, improvements, corrections or other changes without further notice to any product herein. Diodes Incorporated does not assume any liability arising out of the application or use of any product described herein; neither does it convey any license under its patent rights, nor the rights of others. The user of products in such applications shall assume all risks of such use and will agree to hold Diodes Incorporated and all the companies whose products are represented on our website, harmless against all damages.

LIFE SUPPORT

Diodes Incorporated products are not authorized for use as critical components in life support devices or systems without the expressed written approval of the President of Diodes Incorporated.